

ATL-400 LOW PROFILE AUTOMATIC VEHICLE RESTRAINT



FEATURE SUMMARY

- Non-Impact Design
- Barrier Stores 9" High to Escape Impact From Low Rear Impact Guards
- HYDRA-FLOAT™ Barrier Automatically Adjusts to Truck Movement During Loading
- Simple Push Button Operation
- Vertical Locking Hook Secures Virtually All Rear Impact Guards With In Excess of 32,000 lbs. of Restraining Force
- Self Cleaning Guide Track
- Vertical Operating Range From 9" to 30"
- Easy to Install
- Safety System Includes Red/Green Lights and Signs Inside & Outside
- 5 Year Structural Warranty
- Virtually No Required Maintenance
- Housing Encloses Working Parts From Inclement Weather and Debris
- All Weather Zinc Plated Components for Superior Durability
- Mounting Force in Excess of 100,000 lbs.

SPECIFICATIONS

VEHICLE RESTRAINT SYSTEM DESCRIPTION

The TRUCK-LOCK® Series of vehicle restraints improve safety with strength, convenience and reliability.

The ATL-400 is an affordable automatic unit designed to secure a truck at the loading dock by engaging the rear impact guard with a large barrier. The housing/barrier combination is stored down and clear of incoming trucks while protecting working parts from weather and debris.

The HYDRA-FLOAT™ barrier automatically adjusts to various truck heights and maintains position during loading. The operator easily activates and stores the barrier with a push of a button. The low profile barrier stores at only 9" high and raises to 30" to restrain all types of rear impact guards.

OPERATION

With a green outside light, the trailer is backed into position until contacting the dock bumpers. Driver then sets brakes and chocks wheels. Dock attendant pushes a control button, activating the barrier until it contacts the rear impact guard, securing the trailer.

On activation from stored position, outside light will switch to red, and after engagement with the rear impact guard, the inside light switches from red to green. At this time the attendant verifies a proper hitch and, provided the recommended interconnect is utilized, use of dock leveler is permitted.

The barrier provides a restraining force in excess of 32,000 lbs. and adjusts automatically up and down during loading, ensuring trailers are restrained at all times.

When loading/unloading is completed, dock attendant stores the barrier using the release button, the inside light switches to red, and the outside light to green, informing the driver they are allowed to leave the loading dock.

COMMUNICATION

Safety equipment includes flashing red or green inside and outside lights, operator instructions and outside mounted sign with forward and reverse lettering for truck driver.

WARRANTY

One-Year parts and labor & Five-Year structural warranty from date of shipment. Warranties are subject to limitations on liability.

CONSTRUCTION

Enclosed barrier and housing is structurally welded with dual reinforced 1/2" steel restraining arms and 1/4" enclosure panel. The stored housing protects working components from weather, dirt and debris. Dual 1/2" steel reinforced vertical tracks are welded securely to the 3/8" wall mounting plate.

Mounting plate, track, barrier, and lift arms are zinc plated. The control panel is a NEMA 12 rated dust tight enclosure with push button controls, operator instructions and communication lights on the cover.

Black and yellow warning labels are provided on moving barrier.

Power requirement is 120VAC, 3 amps.

INSTALLATION

All Nordock TRUCK-LOCK® Model ATL-400 vehicle restraints are factory assembled and tested.

The restraint is mounted to the dock face and pit floor with concrete wedge anchors and welded to the pit curb angle.

An alternate method is to weld the restraint to a dock face embedded steel plate. Total mounting force is in excess of 100,000 lbs.

Signs, control panel and optional components are installed in accordance with instructions contained in the owner's manual.

DIMENSIONS

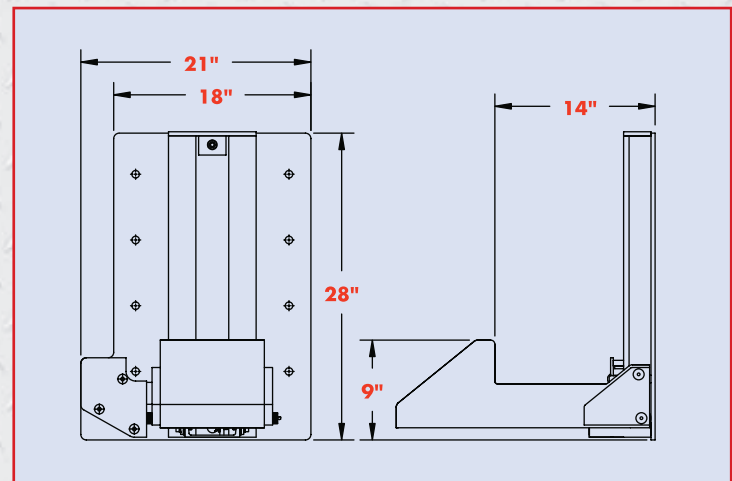

OPTIONS & ACCESSORIES

- Barrier Sensor – Use Model ATL-450
- Barrier Sensor + Alarm – Use Model ATL-500
- Cantilever Extension Mounting Bracket
- Cast-In Wall Mounting Plate
- LED Lights
- Keyed Override Switch